



DD-60 Digital Drum



Users manual

INFORMATION FOR YOUR SAFETY!

THE FCC REGULATION WARNING (for USA)

This equipment has been tested and found to comply with the limits for a Class B digital device, pursuant to Part 15 of the FCC Rules.

These limits are designed to provide reasonable protection against harmful interference in a residential installation. This equipment generates, uses, and can radiate radio frequency energy and, if not installed and used in accordance with the instructions, may cause harmful interference to radio communications. However, there is no guarantee that interference will not occur in a particular installation.

If this equipment does cause harmful interference to radio or television reception, which can be determined by turning the equipment off and on, the user is encouraged to try to correct the interference by one or more of the following measures:

- Reorient or relocate the receiving antenna.
- Increase the separation between the equipment and receiver.
- Connect the equipment into an outlet on a circuit different from that to which the receiver is connected.
- Consult the dealer or an experienced radio/TV technician for help.

Unauthorized changes or modification to this system can void the user's authority to operate this equipment.

CAUTION

The normal function of the product may be disturbed by Strong Electro Magnetic Interference. If so, simply reset the product to resume normal operation by following the owner's manual. In case the function could not resume, please use the product in other location.

PRECAUTIONS

PLEASE READ CAREFULLY BEFORE PROCEEDING

Please keep this manual in a safe place for future reference.

Power Supply

Please connect the designated AC adaptor to an AC outlet of the correct voltage.

Do not connect it to an AC outlet of voltage other than that for which your instrument is intended.

Unplug the AC power adaptor when not using the instrument, or during electrical storms.

Connections

Before connecting the instrument to other devices, turn off the power to all units. This will help prevent malfunction and / or damage to other devices.

Location

Do not expose the instrument to the following conditions to avoid deformation, discoloration, or more serious damage:

- Direct sunlight
- Extreme temperature or humidity
- Excessive dusty or dirty location
- Strong vibrations or shocks
- Close to magnetic fields

Interference with other electrical devices

Radios and televisions placed nearby may experience reception interference. Operate this unit at a suitable distance from radios and televisions.

Cleaning

Clean only with a soft, dry cloth.

Do not use paint thinners, solvents, cleaning fluids, or chemical-impregnated wiping cloths.

Handling

Do not apply excessive force to the switches or controls.

Do not let paper, metallic, or other objects into the instrument. If this happens, unplug the AC adaptor from the wall outlet. Then have the instrument inspected by qualified service personnel.

Disconnect all cables before moving the instrument.

Setting Up	
Power Supply.....	4
Using Headphones.....	5
Control Panel.....	6
Front Panel.....	6
Rear Panel.....	6
Playing the Demo Song.....	7
Playing a Rhythm	
Selecting a Rhythm.....	8
Adjusting the Tempo.....	8
Tap Start.....	9
Chord.....	9
Play the Pads	
Pad Names.....	10
Assign a Voice to Individual Pads.....	10
Playing the Game	
How to Play?.....	11
Starting a New Game.....	11
Coach	
Let a Tutor Coach you.....	12
Specifications.....	13
Appendix	
Percussion Voice List.....	14
Rhythm List.....	14
Demo List.....	15
Coach List.....	15

Setting Up

Power Supply

Your Digital Drum will run either from batteries or power adaptor. Follow the instructions below according to the power source you intend to use.

Using an AC-Adaptor

Connect the power adaptor to the DC IN jack located on the rear panel of the unit, and plug the AC power adaptor into an AC power outlet.

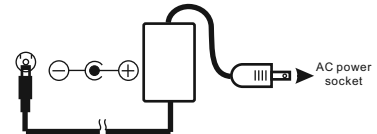

Using Batteries

1. Open the battery compartment cover on the underside of the unit.

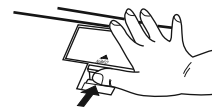

2. Insert six "C" size, R14, SUM-2 or equivalent batteries. When inserting the batteries, be careful to follow the polarity markings in the illustration.

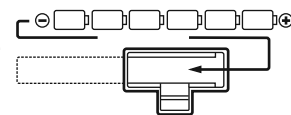

3. Close the battery compartment securely.

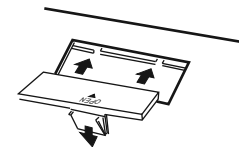

Note:

Power will be automatically drawn from the AC adaptor if an optional AC adaptor is connected while batteries are installed in the instrument.

CAUTION:

It is recommended that you replace worn batteries as soon as possible. When battery voltage drops, the display will dim and/or the sound will become distorted. When this occurs, replace the batteries with a complete set of six new batteries of the same type.

NEVER mix old and new batteries, different types of batteries (alkaline, magnesium, etc.), batteries by different makers, or batteries from the same maker but of different types. Misuse may cause the instrument to become hot, result in fire, or battery leakage.

Also, to prevent damage due to battery leakage, remove all the batteries from the instrument when it is not to be used for an extended period of time. Batteries left in an unused instrument will also lose their power overtime.

Using Headphones

An optional set of stereo headphones can be connected to the Headphones jack located on the rear panel. When a pair of headphones is connected to the jack, the internal speakers of the unit will switch off automatically, perfect for private practice or late night playing. If you want to use an external sound system, the headphone jack can also be used to connect the digital drum to a stereo system or mixing console.

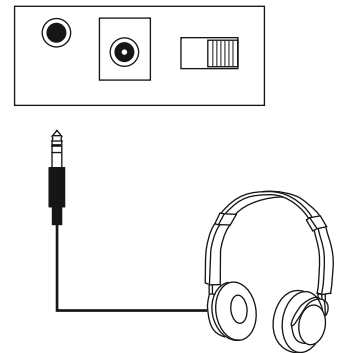

Control Panel

Front Panel

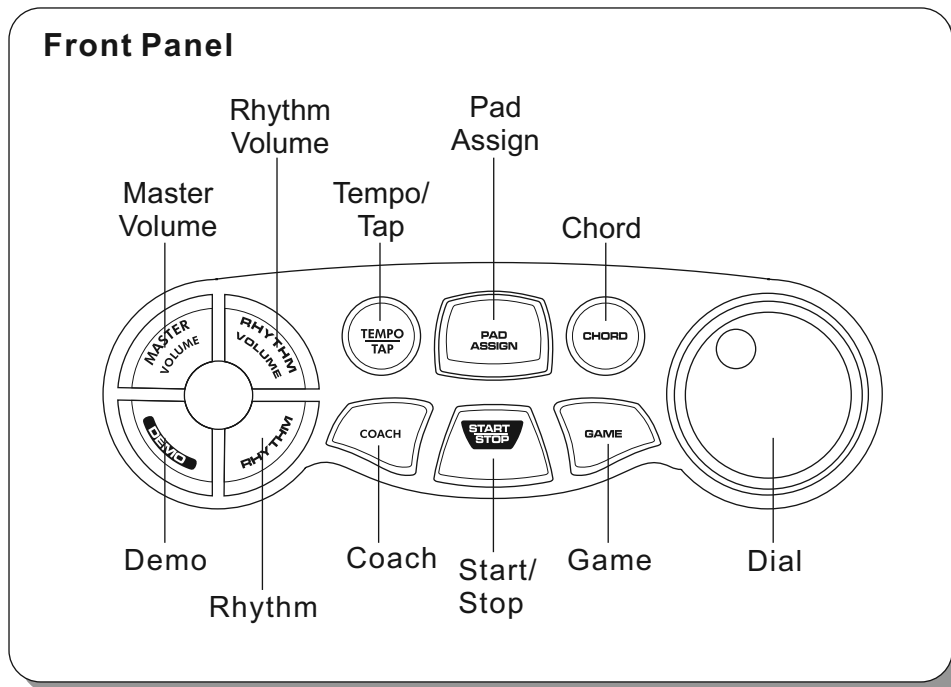

Rear Panel

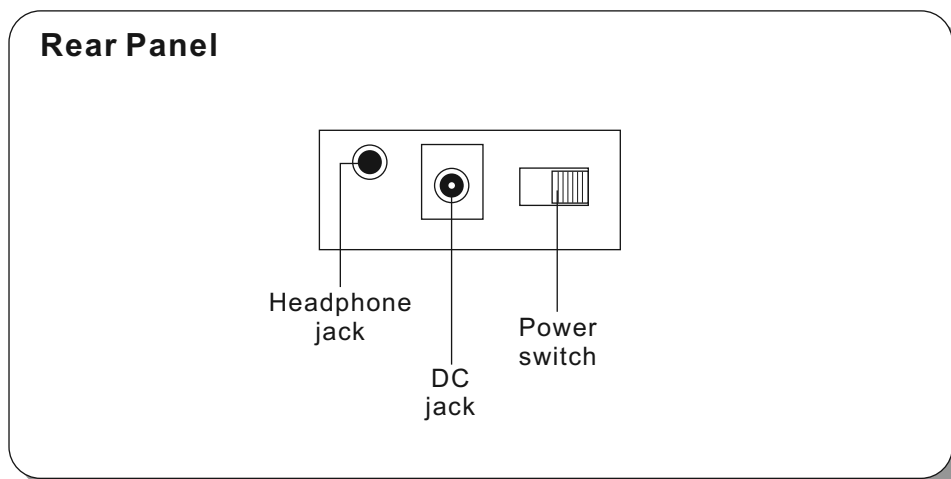

Playing the Demo Song

Your Digital Drum comes with a demo song for showing you the possibilities of the drum. To playback the demo song, follow the instruction below:

1. Turn on the power

Turn the **[POWER]** switch ON.
The LCD display light up.

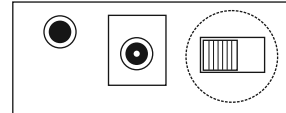

2. Start the DEMO Song

Press **[DEMO]** button, the demo song will start and the indicator of drum pads will flash by following the demo song.

3. MASTER VOLUME

The overall volume level of the instrument is controlled by a **[MASTER VOLUME]** button.

Press the **[MASTER VOLUME]** button and rotate the DIAL to adjust the volume of the Demo song. Rotate the DIAL anti-clockwise to decrease the volume, or rotate clockwise to increase it.

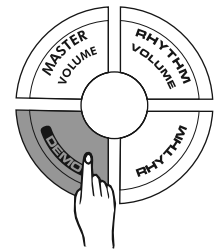

4. RHYTHM VOLUME

The song's volume level is controlled by the **[RHYTHM VOLUME]** button.

The RHYTHM VOLUME can be used to adjust the balance between the song accompaniment and your own performance on the pads.

Press the top **[RHYTHM VOLUME]** and rotate the DIAL to adjust the volume of the song. Rotate the DIAL anti-clockwise to decrease the volume, or rotate clockwise to increase it.

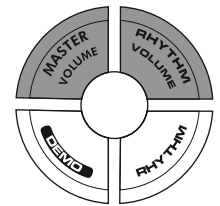

5. Stop the DEMO Song

To stop the demo song, press the **[DEMO]** button again.

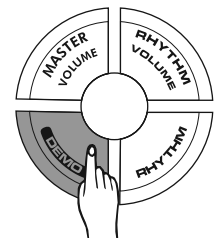

Playing a Rhythm

Your Digital Drum features 50 different rhythms that can be used to provide accompaniment. Select one of the rhythm and listen to it.

Selecting a Rhythm

1. Press the [RHYTHM] button

Press the [RHYTHM] button, the currently selected song number will appear on the display.

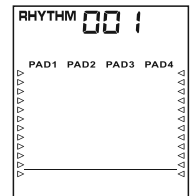
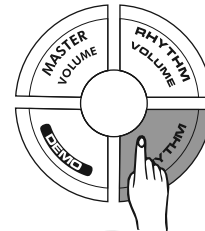

2. Select a rhythm

Use the DIAL to select a rhythm. Rotate the DIAL anti-clockwise to decrease the rhythm number, or rotate clockwise to increase it.

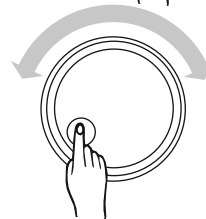

3. Press the [START/STOP] button

Press the [START/STOP] button to start the playback.

Note: You can also use the TAP function to start the songs (see page 8).



Adjusting the Tempo

The tempo of a rhythm can be set anywhere from 40 to 240 beats per minute. As the tempo value increase, the tempo will become faster.

1. Press the [TEMPO/TAP] button

Press the [TEMPO/TAP] button, the current tempo will appear on the display.

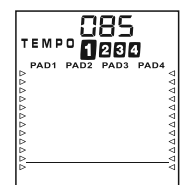

2. Rotate the DIAL

Use the DIAL to adjust the tempo. Rotate the DIAL anti-clockwise to decrease, or rotate clockwise to increase it.

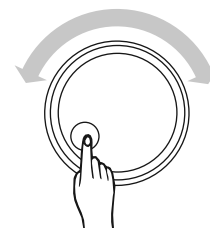

Tap Start

The TAP START function allows you to set the song's overall tempo as well as start the accompaniment. The accompaniment will playback at the tempo with which the pads are struck.

1. Press the [TEMPO/TAP] button

Press the [TEMPO/TAP] button, the current tempo will appear on the display.

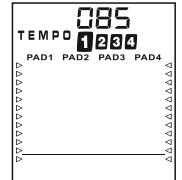

2. Tap Start

Strike any pad three or four times (based on current rhythm's time signature), the accompaniment will start at the desired tempo. The tempo corresponds to the speed of the last 2 times you strike the pads.

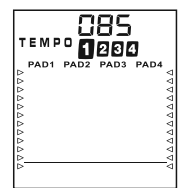

3. Stop the Playback

To stop the playback, press the [START/STOP] button.



Chord

Turn on/off the Chord

You can turn on/off the Chord during the playback or while the accompaniment is in standby state. Press the [CHORD] button once and the status will appear on the display.

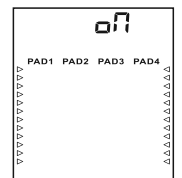

Play the Pads

Pad Names

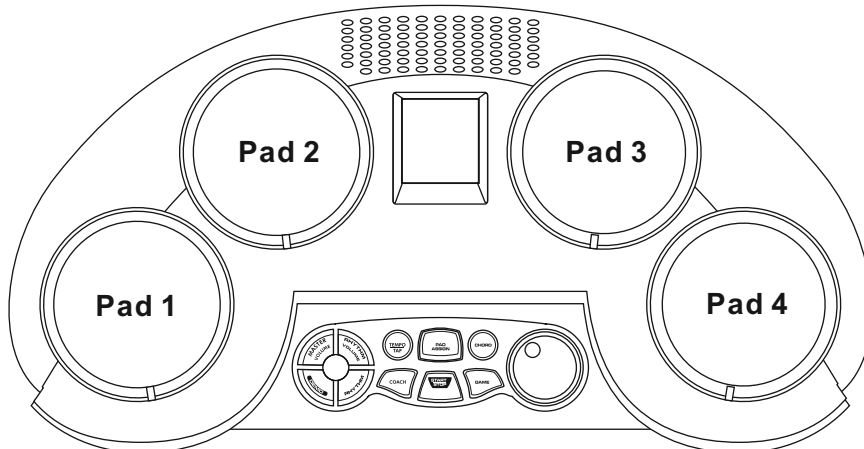

Assign a Voice to Individual Pads

The Digital Drum has a total of 70 percussion sounds and 10 sound effects that can be assigned to each of the 4 drum pads.

1. Select a Rhythm

Rotate the DIAL to select a Rhythm that you want to assign the pads.

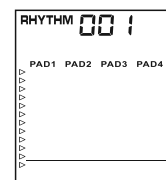
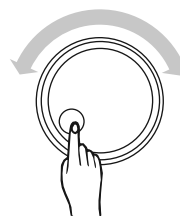

2. Press the [PAD ASSIGN] button

Press the [PAD ASSIGN] button. PAD ASSIGN indicator appear on the display and the indication light below Pad 1 light up.

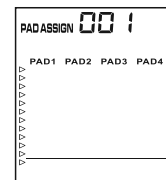

3. Select a Pad

Strike the Drum Pad that you want to assign once, for example, Drum Pad 2, the indicator below Pad 2 light up, and the display show the current percussion and effect sounds number.

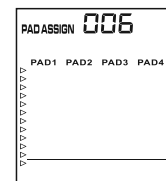

4. Select a Percussion

You can select the voice by striking the pad repeatedly until you reach the voice that you desired.

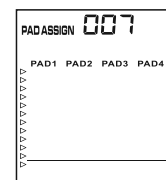

5. Press the PAD ASSIGN Button

When you have finished selecting your desired percussion sound, press the [PAD ASSIGN] button to confirm.



6. Play the Pads

Now you can play your drum with the assigned drum pad. Repeat steps 2-5 if you want to assign another drum pad.

Note:

The most recently assigned percussion sounds will overwrite the percussion sounds assigned previously.

Playing the Game

How to Play?

The Digital Drum's Game feature let the player learn and play a rhythm by following the dropping bars on the screen. When the dropping bars of the pad goes beyond the line at the bottom of the display, strike the corresponding pads.

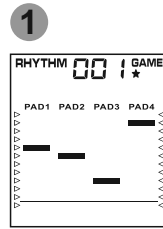

1
The bars of each pads are dropping.



2
When the bar drops beyond the line, strike the pad.
(In the screen shot on the left, strike PAD3)

Starting a New Game

1. Press the [GAME] button

Press the [GAME] button, the GAME indicator appear on the display.

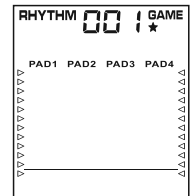

2. Select a rhythm to play

Rotate the DIAL to select a rhythm to play with. Each rhythm has its own level shown below the GAME indicator:

- GAME ★ ~ Easy
- GAME ★★ ~ Normal
- GAME ★★★ ~ Hard

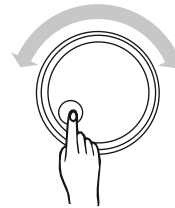

3. Start the Game

Press the [START/STOP] button, the bars of the corresponding pads start falling from the top of the screen. You can strike the pads until the dropping bars of each pad reaches the line at the bottom of the display.

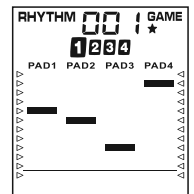

4. Score

After game has finished, it will stop and display your score. You will hear a voice comment according to your performance.

Score	Comment
0-29	OK
30-59	GOOD
60-79	VERY GOOD
80-100	EXCELLENT

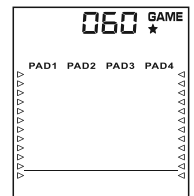

5. Stop the Game

The game will automatically restart after displaying the score for 3 seconds. To stop the game, just press [START/STOP] at anytime. Press [GAME] button to exit Game mode.

Coach

Let a Tutor Coach you

This digital Drum has a Coach function. You can practice basic drum technic following 20 different Coach solo. Just like game, there is also falling bars telling you when to strike drum pads.

1、 Press the [COACH] button

press the [COACH] button, "001" will appear on the display, this is the default coach solo.

2、 Select a coach solo to exercise

Rotate the DIAL to select a solo to exercise. You can select from 1 to 20. Each coach song has its own difficulty level shown on the right of the coach number.

3、 Start a coach solo

Press the [START/STOP] button, the bars of the corresponding pads start falling from the top of the screen, as well as the indication lights of each pad start flashing. You can strike the pads with flashing indication lights, or strike the pads until the dropping bars of each pad reaches the line at the bottom of the display.

4、 Score

After following the coach solo for 3 times, it will stop and display your score. You will hear a voice comment according to your performance.

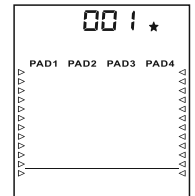

Score	Comment
00-39	OK
40-69	GOOD
70-89	VERY GOOD
90-100	EXCELLENT

5、 Stop the Coach Solo

The Coach Solo will automatically restart after displaying the score for 3 seconds. To stop the coach, just press [START/STOP] at any time. Press [Coach] button to exit Coach mode.

Specifications

Pads:	4 Touch Sensitive Drum Pads with Indication Lights
Drum Voices:	70 Percussion Voices & 10 Effect Voices
Rhythms:	50
Demo Song:	1
Coach Songs:	20
Panel Controls:	POWER ON/OFF, MASTER VOLUME, RHYTHM VOLUME DEMO, RHYTHM, TEMPO/TAP, PAD ASSIGN, CHORD, COACH, START/STOP, GAME, DIAL
Connectors:	HEADPHONES = 9V (AC Adaptor)
Power Source:	Six "C" size, SUM-2, R14, or equivalent batteries
Dimensions:	460(W) X 260(D) X 150(H) mm
Weight:	1.5kg (without batteries)

Appendix

Percussion Voice List

No.	Name	No.	Name	No.	Name	No.	Name
	BASS DRUM	21	Analog Snare Rim		CRASH	60	Tambourine 2
1	Standard Kick 1	22	Analog Snare 2	41	Standard Crash 1	61	Bango Hi
2	Analog Kick 1	23	House Snare	42	Standard Crash 2	62	Bango Low
3	Rock Kick		HI-HAT	43	Standard Crash 3	63	Conga Open
4	Room Kick	24	Hi-hat 1	44	Analog Crash	64	Conga Mute
5	Analog Kick 2	25	Hi-hat 2		RIDE	65	Cabasa
6	Hard Kick	26	Hi-hat & Snare	45	Ride 1	66	Maracas
7	Acoustic Kick	27	Hi-hat & Kick	46	Ride 2	67	Claves
8	Standard Kick 2	28	Standard Hi-hat Close	47	Ride 3	68	Triangle Open
9	Standard Kick 3	29	Standard Hi-hat Open	48	Standard Ride	69	Triangle Mute
	SNARE DRUM	30	Analog Hi-hat Close		PERCUSSION	70	Analog Cowbell
10	Standard Snare 1	31	Analog Hi-hat Open	49	Cowbell 1	71	One
11	Standard Snare 2		TOM	50	Cowbell 2	72	Two
12	Synth Snare 1	32	Standard Tom 1	51	Cowbell 3	73	Three
13	Synth Snare 2	33	Standard Tom 2	52	Timbale Low	74	Four
14	Synth Snare 3	34	Standard Tom 3	53	Timbale 1	75	OK
15	Analog Snare 1	35	Standard Tom 4	54	Timbale 2	76	Good
16	Standard Snare Rim	36	Tom & Snare	55	Timbale & Kick	77	Very Good
17	Standard Snare 3	37	Tom Low	56	Metronome Click	78	Excellent
18	Acoustic Snare	38	Acoustic Tom	57	Metronome Bell	79	FX
19	Rock Snare	39	Rock Tom	58	Hand Clap	80	BLJ Trill
20	Rock Snare Rim	40	Analog Tom	59	Tambourine 1		

Rhythm List

No.	Name	No.	Name	No.	Name	No.	Name
	8Beat	16	Blues Funk	32	Reggae 1	48	SFX 3
1	8Beat		Dance	33	Reggae 2	49	SFX 4
2	8Beat Ballad	17	Pop Dance	34	Bossanova	50	SFX 5
3	8Beat Pop	18	Disco	35	Samba		
4	8Beat Rock	19	House	36	Latin Rock		
5	Rock 1	20	Hip Hop	37	Cha Cha		
6	Rock 2	21	Rap	38	Mambo		
7	Hard Rock	22	Shuffle	39	Rhumba		
8	Heavy Metal 1	23	Slow Rock		Country		
9	Heavy Metal 2	24	Soul	40	Country		
	6/8 Pop		Jazz	41	Country Rock		
10	6/8 Pop 1	25	Cool Jazz		March & Waltz		
11	6/8 Pop 2	26	Jazz Swing	42	March		
	16Beat	27	Blues 1	43	Polka		
12	16Beat Pop	28	Blues 2	44	Waltz 1		
13	16Beat Funk	29	Fusion 1	45	Waltz 2		
	Funk	30	Fusion 2		Sound Effect		
14	Funk	31	Bounce	46	SFX 1		
15	Funk Pop		Latin	47	SFX 2		

Demo List

No.	Name
01	Funk

Coach List

No.	Name	No.	Name
	Rock	11	Latin 3
1	Rock 1	12	Latin 4
2	Rock 2		Conga
3	Rock 3	13	Conga 1
4	Rock 4	14	Conga 2
	Pop	15	Conga 3
5	Pop 1	16	Conga 4
6	Pop 2		Dance
7	Pop 3	17	Dance 1
8	Pop 4	18	Dance 2
	Latin	19	Dance 3
9	Latin 1	20	Dance 4
10	Latin 2		

